

U-TUBE FIXED & REMOVEABLE BUNDLE

HEAT EXCHANGERS

For steam to liquid service

- Operating pressure for tubes 100 PSI.
- Operating pressure for shell 100 PSI.
- Operating temperature 400 °F.
- Can be customized to fit any application.
- Computer generated data sheet available for any application
- As an option, available in ASME Code and Certified

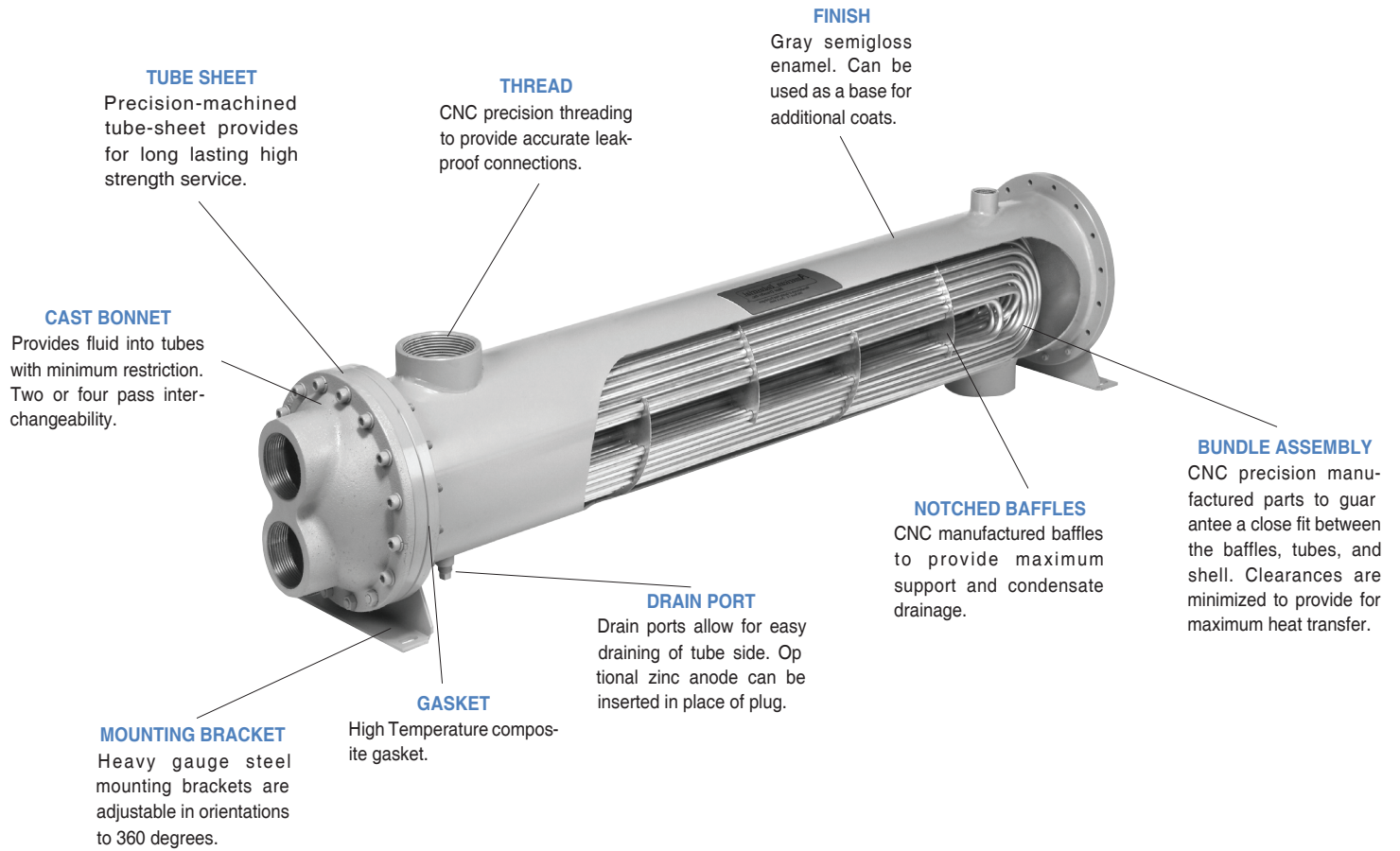

STANDARD CONSTRUCTION MATERIALS & RATINGS

Standard Model	UCN	Options	Standard Unit Ratings
Shell	Steel	Stainless Steel	Operating Pressure Tubes 100 psig Operating Pressure Shell 100 psig Operating Temperature 400 °F
Tubes	Copper	90/10 Cu. Ni. / Stainless Steel	
Baffles	Aluminum / Brass	Stainless Steel	
Tube Sheet	Steel	Brass / Stainless Steel	
End Bonnets	Cast Iron	Stainless Steel	
Mounting Brackets	Steel	Stainless Steel	
Gasket	High Temperature Gasket	Viton	

UCN Series

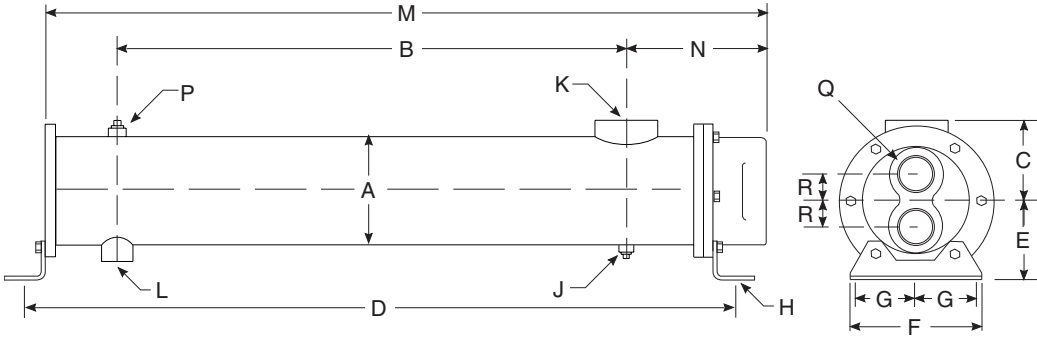

TWO PASS (TP)

Model	M	N	Q NPT	R
UCN-1024	28.88			
UCN-1036	40.88	6.00	1.50	1.19
UCN-1048	52.88			
UCN-1224	29.17			
UCN-1236	41.17	6.67	2.00	1.44
UCN-1248	53.17			
UCN-1260	65.17			
UCN-1272	77.17			
UCN-1284	89.17			
UCN-1724	30.13			
UCN-1736	42.13	7.88	2.50	1.88
UCN-1748	54.13			
UCN-1760	66.13			
UCN-1772	78.13			
UCN-1784	90.13			
UCN-2036	43.91			
UCN-2048	55.91	10.16	3.00	2.50
UCN-2060	67.91			
UCN-2072	79.91			
UCN-2084	91.91			

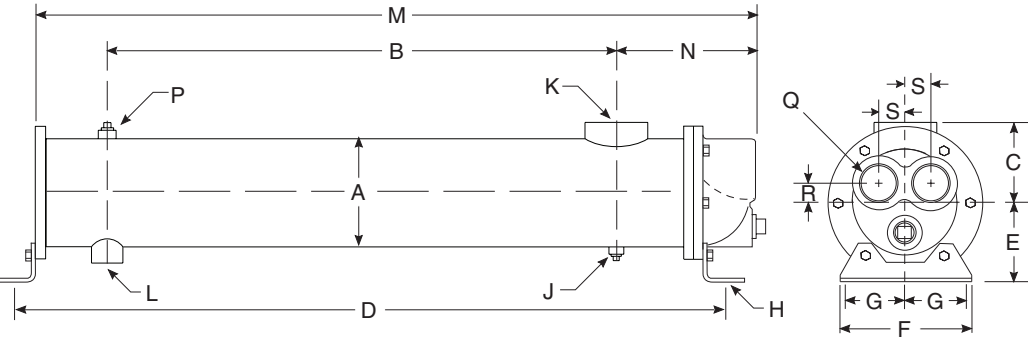

FOUR PASS (FP)

Model	M	N	Q NPT	R	S
UCN-1024	29.21				
UCN-1036	41.21	6.34	1.00	.75	1.19
UCN-1048	53.21				
UCN-1224	29.58				
UCN-1236	41.58	7.08	1.50	1.06	1.44
UCN-1248	53.58				
UCN-1260	65.58				
UCN-1272	77.58				
UCN-1284	84.58				
UCN-1724	29.78				
UCN-1736	41.78	7.53	2.00	1.38	1.88
UCN-1748	53.78				
UCN-1760	65.78				
UCN-1772	77.78				
UCN-1784	89.78				
UCN-2036	44.00				
UCN-2048	56.00	10.26	2.50	1.75	2.50
UCN-2060	68.00				
UCN-2072	80.00				
UCN-2084	92.00				

COMMON DIMENSIONS

Model	A	B	C	D	E	F	G	H	J NPT	K NPT	L NPT	P NPT	Weight	Model
UCN-1024				29.13									55.00	UCN-1024
UCN-1036	5.25	32.00	3.69	41.13	4.00	5.25	2.00	.44 x 1.00 thru slot	.375	2.00	1.50	.75	70.00	UCN-1036
UCN-1048		44.00		53.13									85.00	UCN-1048
UCN-1224		19.00		29.59									83.00	UCN-1224
UCN-1236		31.00		41.59									108.00	UCN-1236
UCN-1248	6.25	43.00	4.19	53.59	4.50	6.25	2.50	.44 x 1.00 thru slot	.375	2.50	2.00	.75	132.00	UCN-1248
UCN-1260		55.00		65.59									158.00	UCN-1260
UCN-1272		67.00		77.59									182.00	UCN-1272
UCN-1284		79.00		89.59									206.00	UCN-1284
UCN-1724		19.00		29.50									138.00	UCN-1724
UCN-1736		31.00		41.50									180.00	UCN-1736
UCN-1748	8.00	43.00	5.06	53.50	5.75	8.25	3.50	.44 x 1.00 thru slot	.375	3.00	2.00	1.00	219.00	UCN-1748
UCN-1760		55.00		65.50									258.00	UCN-1760
UCN-1772		67.00		77.50									300.00	UCN-1772
UCN-1784		79.00		89.50									342.00	UCN-1784
UCN-2036		30.00		42.63									620.00	UCN-2036
UCN-2048		42.00		54.63									670.00	UCN-2048
UCN-2060	10.75	54.00	6.88	66.63	8.00	11.50	5.00	.781 x 1.25 thru slot	.50	4.00	3.00	1.25	730.00	UCN-2060
UCN-2072		66.00		78.63									820.00	UCN-2072
UCN-2084		78.00		90.63									870.00	UCN-2084